



Indira Paryavaran Bhawan: India's First Net Zero Building

By Shashanka Tiwari

*Business Execution Head, Domestic Projects Group
Voltas Limited, New Delhi*

Introduction

Indira Paryavaran Bhawan, inaugurated on February 25, 2014 is a new centrally air conditioned office building for the Ministry of Environment and Forests to accommodate more than 600 government officials. Located at Jor Bagh Road, New Delhi, it is the first Net Zero building in India with LEED Platinum certification and GRIHA Five Star certification for Exemplary Demonstration of Renewable Technologies.

The total energy consumption is 14 lakh kWhr (as compared to 22 lakh kWhr that would have been required for a similar conventional building) in a year, and the same amount of energy is being generated through solar cells; hence the net energy consumption for the building is zero. The building has been designed to reduce the overall electrical energy requirement as compared to a conventional building. Since electrical power requirement for HVAC comprises a major share of overall building power requirement, HVAC played a major role in achieving the Net Zero criteria for the building. In order to minimize electrical energy for the HVAC system, innovative HVAC and building design methodology along with innovative products have been introduced for the first time.

Innovative Technologies Used in the Project

The following technologies and products have been used for

the first time for such a large project in India:

- (a) Highly energy efficient VFD driven screw chillers with IKW of 0.56 kW/TR.
- (b) Use of geothermal heat exchange system for cooling of condenser water instead of conventional cooling towers. This reduces energy consumption by avoiding cooling tower fan motor and conserves water. In this system, 180 vertical holes of 100mm diameter (80m deep) have been made in the ground to run HDPE closed loop pipe system for rejection of condenser heat into the earth surface. Such large scale heat rejection (180 TR) through geothermal technology has been achieved for the first time in India.
- (c) Use of vertical coil chilled beams (induction units) with drain pans. 77% of the building has been air conditioned using chilled beam technology instead of the conventional air handling units and fan coil units. These chilled beams do not

About the Author

Shashanka Tiwari has been in the HVAC Industry for more than 15 years. He has headed the design and planning department of Voltas Delhi for several years, and has designed and executed many projects such as Commonwealth Games stadiums, National Physical Laboratory and Indira Paryavaran Bhawan with stringent inside design conditions, and Data Center Projects. He is currently looking after project management and execution in North India for Voltas.

continued on page 62

continued from page 60

have any moving parts and electrical components; however, they are able to produce three times the secondary air than the primary input air, using innovative nozzles.

Chilled beams with drain pan having vertical coils have been used for the first time in India, instead of conventional chilled beams with horizontal coils without drain pans. This was done in order to avoid condensation, which was a requirement for the building as per the specified design conditions. Use of chilled beams reduces the capacity requirement of the primary air handling units, thereby reducing the fan and motor capacities and resulting in energy savings.

- (d) Use of energy efficient heat recovery units. These units use the thermal energy of chilled exhaust air to cool fresh air for the building, reducing the overall load on chillers.
- (e) Use of variable pumping system for chilled water circulation.
- (f) Use of variable frequency drives for all AHUs and cooling tower (used only for the conventional system), reducing energy consumption.
- (g) Use of variable air volume boxes for public areas and meeting halls in the conventional system to regulate air flow requirement, resulting in power savings.
- (h) Use of BMS to regulate energy requirement. Two way PIC valves have been used for all AHUs along with motorized butterfly valves.

Through the use of these innovative technologies, it was possible to save 55 to 70 kW of electrical energy.

HVAC System Details

Total air conditioned area: 1,20,000 sqft
 Area air conditioned with chilled beams: 93,000 sqft
 Load: 310 TR (200 TR by chilled beams, 110 TR by primary air AHUs)
 Area air conditioned with conventional system: 27,000 sqft
 Load: 130 TR

Ventilated area: 1,06,400 sqft (three basements)

Equipment

Screw chillers: 240 TR x 2 (one standby), 200 TR x 1 along with variable pumping system and cooling towers (only for conventional system)
 AHUs: 23 units for chilled beams, 9 units for conventional system
 Heat recovery units: 2
 Chilled beams: 376
 Geothermal system: for heat rejection of 180 TR
 Ventilation fans: 16 for smoke extraction, 24 for normal ventilation
 VAV boxes: 24
 BMS: Two way PIC valves along with motorized butterfly valves
 Air cooled DX type packaged units: 3

How do Chilled Beams Work?

A chilled beam system works on the principle of distributing the cooling with cold water and dimensioning the supply air to meet the requirement of good air quality. Supply air beams (also known as active beams) operate through induction. The incom-

ing supply air brings room air with it, which is sucked in through the coil of the beam. The total flow, which is the sum of supply air and circulation air flow, arrives through the outlet slot of the beam. The circulating air flow with room air is 3-4 times as large as the supply air flow.

Active beams contain a supply air plenum making heat transfer more effective due to forced convection. Primary air is supplied directly into the plenum where it exits via nozzles along its length. Please see *Figure 1*. Air leaving the nozzles induces room air through the heat exchanger.

The mixture of supply air and induced air is introduced into the room through the longitudinal slots along both sides of the beam. With greater heat transfer between the secondary room air and the heat exchanger, active beams are better suited for spaces with higher loads than static beams. Depending on requirements, available space and beam positioning, it is possible to supply air in one or two directions. The induction rate varies between 1:3 and 1:5 depending on the model. A chilled beam takes a source of primary air at an inlet static pressure ranging from 0.4" to 1" WC. It distributes this air through a bank of specially designed aerodynamic nozzles and discharges the air at a high velocity into a mixing chamber. This creates a differential pressure, which enables a draw of room air across a coil. This imparts either sensible cooling or heating to the air as it passes over the coil. The primary air and induced air are mixed and discharged through a grille in a *coanda effect* air distribution at the ceiling. This air circulates throughout the room and is gently drawn back up through the return section of the chilled beam grille. Because the return air to the terminal is located at the ceiling and is moving so gently, dirt is not carried along with it and filters are not required to protect the coils. This eliminates the cost and labour required for routine maintenance.

Figure 3 is a schematic drawing, and *Figure 4* shows the working of a chilled beam.

Chilled Beam Selection

Chilled beam is selected based on latent load and sensible load of the area to be air conditioned. For sensible cooling, the chilled beam has a cooling coil fed through a dedicated chilled beam chiller running at 16/20°C. For latent load, primary air

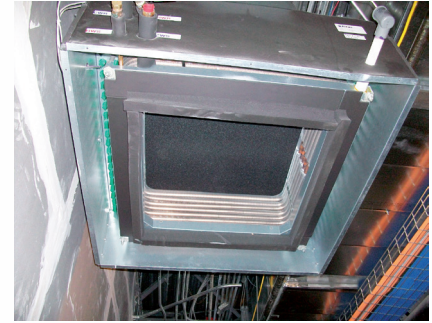

Figure 1: Inside details of chilled beam with coils and nozzles (shown in green)

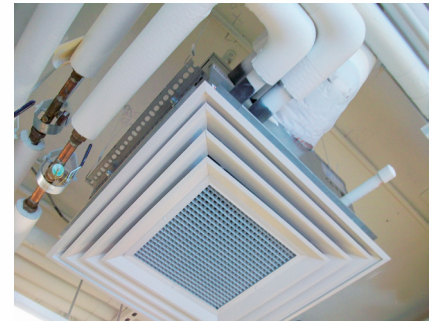

Figure 2: Chilled beam with pipe connections

continued from page 62

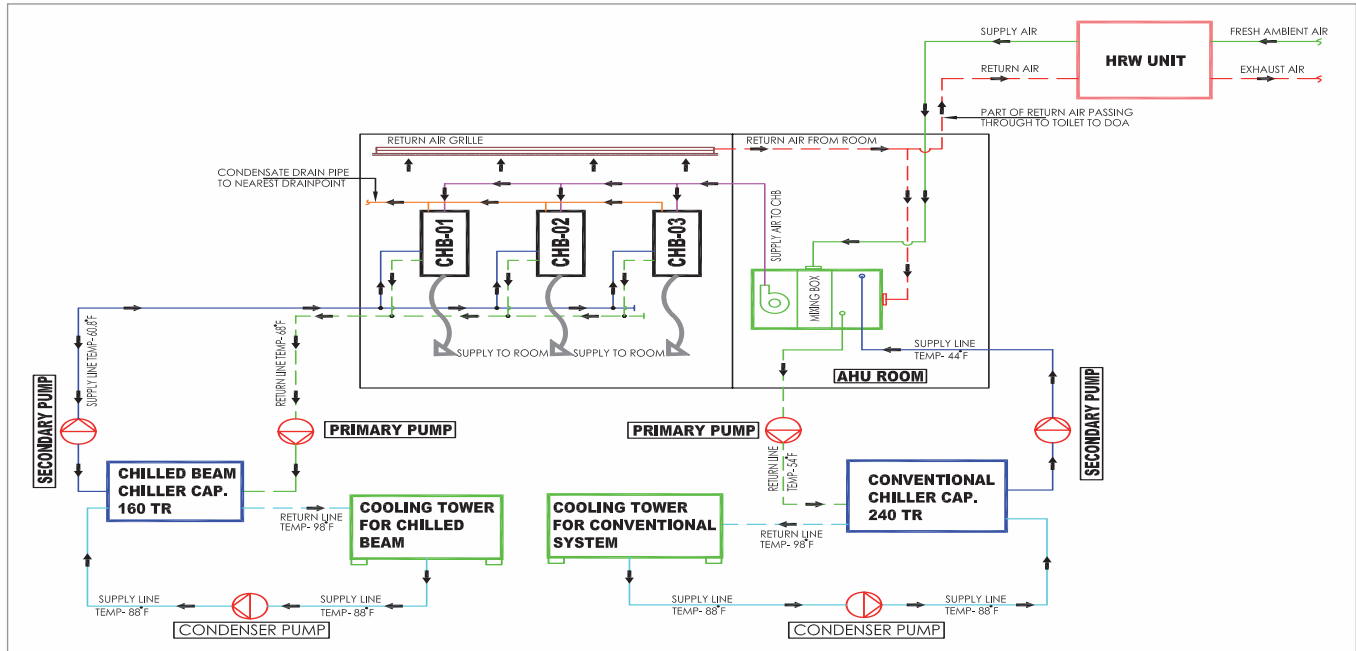

Figure 3: Schematic drawing of a chilled beam

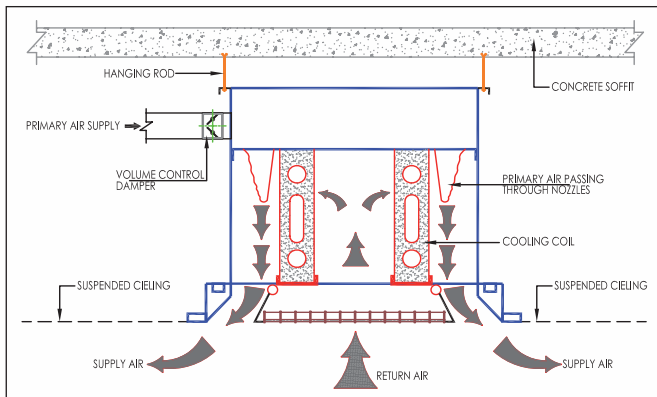

Figure 4: Working of a chilled beam

is fed through a primary air AHU served by normal chillers running at 7/12°C.

Inside design conditions: 26±1°C with 55±5% RH.

Advantages of Chilled Beam Systems

a. Power Saving

Chilled beams are extremely flexible and enhance the savings and effectiveness of primary air systems such as those using dedicated outside air. When using chilled beams, the primary air system, which includes the dedicated outside air unit and the supply and exhaust ductwork, can be sized to handle only the required ventilation air.

Table 1: Example of basic chilled beam calculation

Coil sensible BTU:	
GPM x ΔT x 12000/24	
Primary air sensible BTU:	
Primary air cfm x 1.08 x (return air temperature - primary air temperature)	
Primary air latent BTU:	
Primary air cfm x 0.68 x (return air grains - primary air grains)	

Cycle of air before entering chilled beam

Supply air condition at 24°C DBT/55% RH:

Fresh air - DOA			
cfm	1300		
DBT	66		
WBT	56.71		
Gr	53.92		
BTU	24.24		
RH%	56.57		
Parameter	Return air condition	After coil	Primary air condition
Season	Summer	Summer	Summer
cfm	2700	2700	4000
DBT	77	57	59.93
WBT	63.5	53.5	54.54
Gr	67	58	56.67
BTU	28.769	22.10	22.79
RH%	50	83.19	74.54
TR 6.68			

Cycle of air inside chilled beam

Supply air condition at beam outlet for maintaining room at 24°C DBT/55% RH:

Primary air condition			
cfm	154		
DBT	59.93		
WBT	54.54		
Gr	56.67		
BTU	22.79		
RH%	74.54		
Parameter	Return air condition	After coil	Air outlet condition at beam
Season	Summer	Summer	Summer
cfm	360	360	514
DBT	77	64.1	62.85
WBT	63.5	58.5	57.31
Gr	67	65	62.50
BTU	28.769	25.32	24.56
RH%	50	74	74.16
TR 0.460			

continued on page 66

continued from page 64

Building Features

Energy Savings

- Large savings in HVAC system by using high efficiency measures like precooling of air through geothermal heat exchange and use of renewable energy in part.
- Lifts, toilets, service cores placed on east and west sides and office areas mainly facing the south and north to reduce air conditioning load.
- Zoning to create high conditioned areas and only ventilated areas and optimizing the air conditioning parameters by opting for ambient air temperature more appropriate to Indian conditions. (Every degree increase in ambient air temperature reduces air conditioning load by as much as 8%).
- Reducing fan power by using Displacement Ventilation System with air-supply from the bottom and exhaust from top.
- Roof-top solar thermal air conditioning by using Vapour Absorption Method (VAM) machines and hybridization with PNG fed absorption chillers.
- High efficiency screw chillers using refrigerants which have almost zero ozone depletion potential.
- Use of recycled waste-water for air conditioning.

Architectural Features

- Priority for pedestrians in the front with vehicular access on the sides.
- Appropriate building envelope design by orientation specific shading devices and envelope insulation to reduce heat intake.
- Preservation of maximum possible number of trees standing at site.
- Use of permanent, durable and local materials such as sand stone on exterior face, low heat transmission glass, reflective roofing.
- Use of ECBC compliant designing practices.
- Adoption of universal design parameters to provide barrier free movement for physically challenged.
- Intelligent Building Management System to optimize energy usage through occupancy sensors, fire prevention and fighting and parking management.
- Highly sensitive security systems including access control using bio-metric smartcar readers. Radio frequency tags, CCTV surveillance etc.
- Reduction of conventional lighting load by ensuring 75% day-light use as per LEED requirement.
- Generation of energy by deploying thin film transparent PV modules on spaceframe over the court-yard.
- Usage of high efficiency lighting fixtures, astronomical/time switches and occupancy sensors.

Environmental Prevention and Resource Conservation

- Zero or near zero discharge from the building-both solid and liquid.
- Use of water-efficient sanitary fixtures to reduce water-use, and treated effluent for flushing etc.
- To aim at the goal of carbon neutrality and reduction of global warming.

This reduces the size of the equipment and ductwork, making it easier to fit into a building space. This also reduces the energy required to supply ventilation to the building. The total room air circulation is created solely by the induction principle within the terminal; therefore, there is no electric motor requiring an electric power source or maintenance of fan and motor. A chilled beam is, thus, a quiet and efficient way to provide comfort in a space.

b. Simple to Design and Control

Chilled beams need a constant volume supply air system. They make ASHRAE standard 62 ventilation calculation easy, and result in less complicated AHU and terminal unit controls. There is no cooling coil condensate.

c. Smaller Ductwork

Since 50% - 65% less supply air is required, it results in smaller ductwork and lower size AHUs. It needs less ceiling space. Compared to a large VAV system (50,000 cfm and higher), a chilled beam system can reduce ceiling space by as much as 18 inches. Compared to a small VAV system (20,000 cfm and less), a chilled beam system can reduce ceiling space by 12 Inches.

d. Less Mechanical Space

Chilled beam systems require less building floor area, smaller mechanical room and reduced mechanical shaft size.

e. Lower Construction Cost

As a result of the above, building construction cost comes down and floor to floor height is reduced.

f. Less Maintenance

Chilled beams require almost no maintenance, since there are no moving parts and no filters to maintain. Most manufacturers' units are easily serviced through a removable room air inlet grille. They require minimal cleaning, since they typically remain dust and dirt free.

g. Increased Comfort

Overall occupant comfort is improved, individual room temperature control is achieved at minimal additional cost, system noise is lower due to lower velocity and pressure drop of the constant volume system and absence of VAV boxes, there is better control of space humidity levels and more uniform space temperature, and occupants are less likely to feel cold drafts.

h. Improved Indoor Air Quality

Better than ASHRAE Standard 62 ventilation rates can be achieved, and there is no contaminant mixing,

i. Higher Efficiency

Up to 30% reduction in energy use is achieved due to reduced fan energy, suitability for energy recovery, and higher design chilled water temperature.

j. LEED Points

An additional 8-10 LEED points can be achieved by using chilled beams.

Limitations of Chilled Beams

- a. Chilled beams are not very well known in our country yet, though they are beginning to be utilized more in the USA. They have been a proven technology in Europe for the last 20 years.
- b. They have a higher construction cost compared to VAV.
- c. They affect the traditional ceiling appearance. Chilled beams are larger than traditional ceiling diffusers, and can present challenges for lighting coordination.

continued on page 84

continued from page 66

- d. Building must have good control of humidity to prevent condensation on chilled beam surface.

Conclusion

This project has demonstrated the following advantages of chilled beams:

- Chilled beam with a drain pan having vertical coils has been a success for this project. There is no condensation problem in the entire building. On the other hand, projects commissioned with chilled beams having no drain are facing severe issues of condensation. Hence, for Indian conditions (with high ambient temperature and RH), use of chilled beam with drain pans is advisable.
- Drain pan gives the flexibility to reduce the water temperature through chilled beam coils, maintaining room temperature at a comfortable 24°C.
- Chilled beam has helped in reducing power consumption for the building.
- It has also helped in reducing the AHU capacity, increasing the usable office space.
- There is no maintenance required.
- Uniform cooling distribution has been achieved with lesser noise.
- In conjunction with geothermal technology and other energy efficient products used in this project, chilled beam has played a major role in energy conservation. ❖