

AIR CONDITIONING AND REFRIGERATION Journal

The magazine of the Indian Society of Heating, Refrigerating and Air Conditioning Engineers

Issue : July-September 1999

Control of Cooling-Only VAV BOXES - Part 3



By Rob Moulton

Director, Southeast Asia

Johnson Controls

Rob has been visiting India for more than a decade and making presentations on energy management topics. A part of his current responsibilities include input to world-wide BAS product development.

Import liberalization has made variable air volume air conditioning a viable option for many new Indian office designs. To date, hundreds of VAV boxes have already been installed in India on projects such as Citibank, Colgate Palmolive, Arthur Anderson, Enjay Hotels, JP Morgan, Reliance Centre, Smithkline Beecham, Blue Star House, Sahyadri Guest House, World Bank and IT Park Bangalore. Previous articles addressed the design issues associated with VAV system and the control of the VAV AHU. This article explains the control of cooling-only variable air volume boxes. The next article in the series will discuss Indoor Air Quality Control with VAV systems.

There are many types of VAV boxes. As shown in **Figure 1**, projects in Southeast Asia use a cooling-only application because there is little or no need for heating.

This article describes the control algorithm used in cooling-only VAV boxes. Other types of VAV boxes use this algorithm as a starting point and add a heating control loop to

control the hot water valve, stages of electric reheat or amount of air from the hot deck.

Fig 1 - Types of VAV boxes used by region

	North America	Europe Southeast	Asia
Cooling only	44%	11%	100%
Hot Water Reheat	27%	71%	0%
Electric Reheat	22%	10%	0%
Dual Duct	7 %	8%	0%

As shown in **Figure 2**, there are four modules in a cooling-only VAV controller algorithm. These modules are executed sequentially. The algorithm adjusts airflow through the VAV box to maintain a space temperature using "cascade control" (i.e. the temperature control loop determines the set-point of the flow control loop). In this article, we will take a closer look at each of the modules.

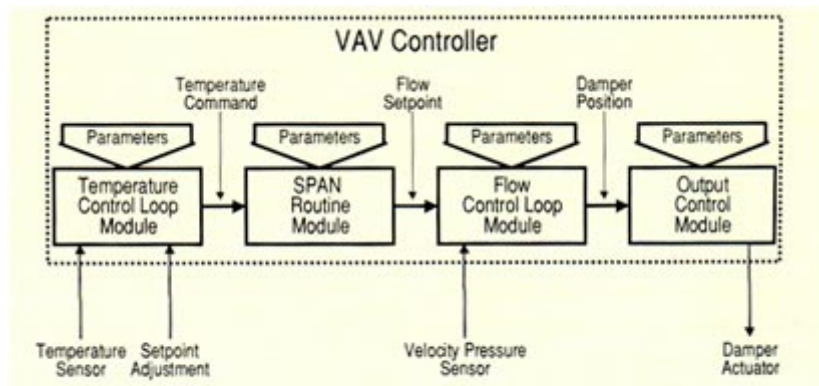

Figure 2 – Modules in a Cooling-only VAV controller algorithm

Temperature control loop module

The temperature control loop compares the zone with a working set-point and uses a PI control algorithm to compute an internal "temperature command" value between 0% and 100%.

As mentioned in the first article in this series, the location of the zone temperature sensor is very important to proper system operation. The system will be controlled so that the temperature at the location of the sensor achieves set-point and therefore the location of the sensor is important for occupant comfort.

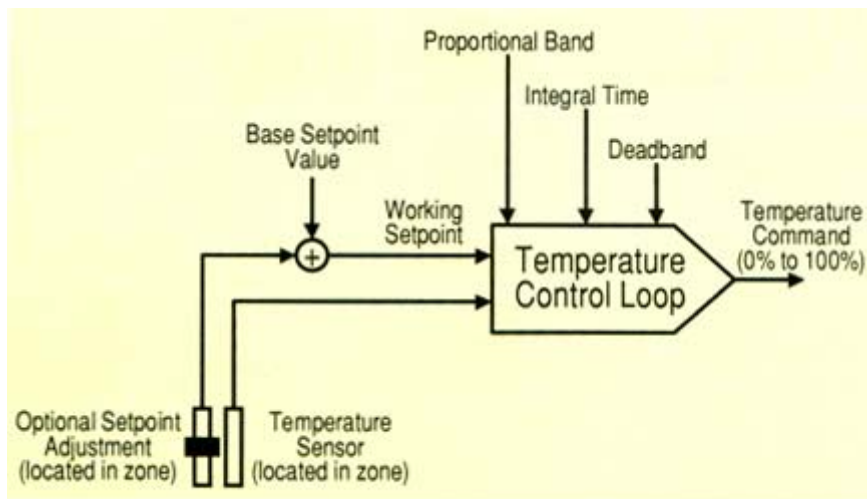

Figure 3 – Details of temperature control loop module

The working set-point for the temperature control loop is calculated by taking a base value and adding or subtracting an offset. The base value can also be made a function of the mode of operation (i.e. different base values for occupied mode, unoccupied mode and standby mode). In Southeast Asia, the system is operated in the occupied mode whenever the AHU is on and the unoccupied modes and standby mode are not used. The base set-point value is typically controlled by the Building Automation System (BAS) operator. If a BAS operator receives a complaint of it being too cold in a zone, the BAS operator will increase the base set-point value. As mentioned in the previous article, an optimization algorithm may change the base set-point when the Air Handling Unit does not have sufficient capacity to meet the total load requirements.

The designer specifies whether occupants will have the ability to fine-tune the temperature set-point for their zone by adjusting the slider or dial on the sensor. There are valid arguments for both allowing and disallowing occupant fine-tuning of temperature set-points. If occupant fine-tuning is disallowed, the working set-point of the control loop is the same as the base set-point value which is either added to or deducted from the base set-point to calculate the working set-point for the temperature control loop. The maximum range of the offset can be fixed in the controller. For example, if the base set-point (established by the BAS) is 22 deg C and the maximum range of the offset is set at ± 2 deg C (a typical default value), the occupant would be able to adjust the working set-point for the temperature control loop between 20 deg C and 24 deg C.

- The system being controlled is non-linear. The optimal tuning parameters under low load conditions will be different from the optimal tuning parameters under high load conditions.

- The system is very slow in responding, the time constant of the control loop can vary between 300 and 600 seconds.

Because the temperature control loop is very difficult to use high values (defaults) for tuning parameters. Using high values for tuning parameters avoids the problem of actuator cycling but results in a slower than optimal response characteristic. There is work being done to apply an adaptive supervisory algorithm that constantly updates the tuning parameters of the control loop.

When this type of algorithm is applied, the impact will be to significantly improve the responsiveness of the VAV box and provides more accurate temperature control.

Span Routine module

The Span Routine takes the temperature command, a value between 0% and 100% and converts it to a set-point for the flow control loop. The Span Routine calculates a set-point between the minimum airflow and the maximum airflow, based on the temperature command value. If the temperature command is 0%, the Span Routine fixes the flow set-point at the minimum airflow. If the temperature command is 100%, the Span Routine fixes the flow set-point at the maximum airflow. If the temperature command is 50%, the Span Routine fixes the flow set-point at a value half way between the minimum airflow and the maximum airflow.

As mentioned in the first article in this series, the maximum airflow parameter is determined by the designer based on the heat load calculations for the zone. The maximum airflow parameter and the required noise level are important parameter is selected to maintain at least six air changes per hour and is typically about 30% of the maximum airflow.

Flow control loop module

The flow control loop compares the calculated airflow with the set-point computed by the SPAN Routine and uses a PI control algorithm to compute an internal "damper position" value between 0% and 100%.

To calculate the airflow, the VAV box has two sets of probes that connect to a differential pressure sensor. One set of probes is mounted facing the air stream to measure the total duct pressure. The second set of probes is mounted facing away from the air stream to measure the duct static sensor measures the difference sensor measures the

difference between the total pressure and the static pressure. The difference signal is the velocity pressure and can be used to calculate the airflow.

The Box Area is typically entered at the factory. The "K" factor may be pre-set at the factory or defined in the field. The "commissioning" of a VAV box typically involves measuring the actual airflow using a portable airflow measuring device (a "hood") and then adjusting the "K" factor so that the VAV controller shows the correct reading.

The flow control loop is very difficult to tune. The relationship between damper position and airflow is non-linear. When the damper first starts to open, airflow increases quickly and large tuning parameters are required for stability. When the damper is almost open, airflow increases slowly and small tuning parameters are required for responsiveness.

The process being controlled by temperature control loop had a very long time constant, but this is not the case for the flow control loop. Pressure changes travel at the speed of sound and the velocity pressure sensors typically have a time constant of about 30 milliseconds. The response of the control loop is dominated by the characteristic of the actuator. Consequently, friction and hysteresis of the actuator introduce additional non-linearity into the process being controlled. The flow control loop uses a Proportional plus Integral (PI) algorithm to calculate a desired damper position. The Output Control Module uses a Position Adjustment (PA) algorithm to control the VAV Box damper. It can be shown mathematically that the effect of combining PI and PA is that the system functions like a Proportional plus Derivative (PD) controller. A derivative component is very sensitive to changes in input signal. This is unfortunate, as the input signal (calculated airflow) is prone to rapid changes (it is a "noisy" input signal). Each time any VAV box changes damper position, the impact is immediately felt by all other VAV boxes connected to the same AHU. To ensure stability, the flow control loop requires a relatively large dead-band of 50 CFM or greater. A large dead-band will decrease the accuracy of control and slow the responsiveness of the loop.

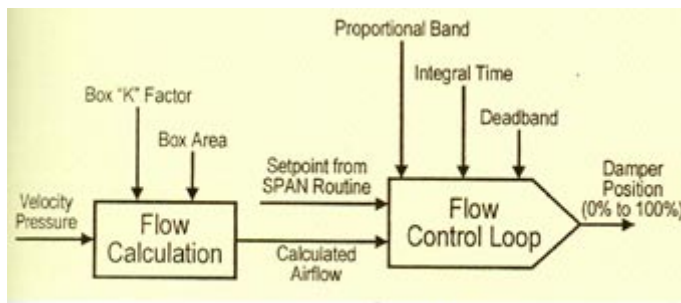

Figure 4 – Details of flow control loop module

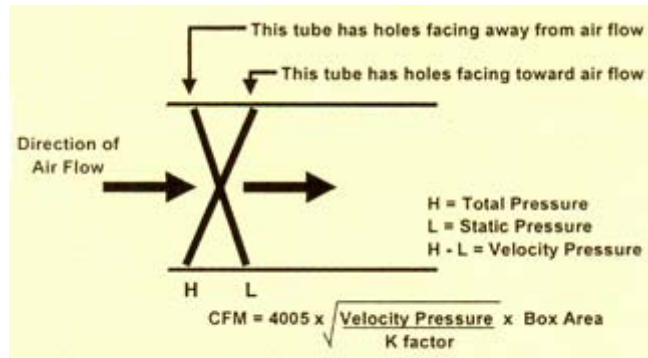

Figure 5 – Flow measurement in VAV box

For the reasons listed above, industry practice is to use high values (defaults) for tuning parameters. Using high values for tuning parameters avoids the problem of actuator cycling but results in a slower than optimal response characteristic. There is work being done to apply an adaptive supervisory algorithm that constantly updates the tuning parameters of the control loop. When this type of algorithm is applied, the impact will be to significantly improve the responsiveness of the VAV box and provide more accurate flow control.

Output control module

Most VAV boxes use an incremental actuator, a synchronous AC motor with dual windings, to control damper position. A VAV box actuator connects to the controller with three wires; common, open and close. A voltage (typically 24VAC) applied between the common and open terminals will cause the actuator to open at a constant rate. A voltage applied between the common and the close terminals will cause the actuator to close at a constant rate.

It is common to indicate the rate of an actuator by stating the stroke time. Stroke time is the time required for the actuator to move closed position (a rotation of 90°). It is common to find VAV actuators with stroke times of 60 to 120 seconds. An actuator with a stroke time of 60 seconds has a constant rate of 1.5°/ second. Since 90° is 100% open, this can also be expressed as 1.67% / second.

The output control module can command the position of the actuator to any value between 0% (fully closed; 0°) and 100% (fully open; 90°) by issuing a 24VAC pulse of known duration to either the open or the closed terminal. To calculate the width of the pulse to be applied to the actuator, the output control module compares the current damper position with the desired damper position (as calculated by the flow control module) and uses the actuator stroke time. For example, if the output control module wants to increase the damper position from 50% to 70% using an actuator with a 60 second stroke time, a 24VAC pulse of 33 seconds $[(170 - 50) \times 100/60]$ is applied between the common and open terminals. This is commonly called a pulse-width modulated (PWM) control signal.

BAS interfacing

As can be seen from the above discussion, there are many parameters, inputs and calculated values stored in the VAV controller. To optimize the size of the real-time database and avoid unnecessary network communications, only some of the information available inside the VAV controller is constantly reported to the Building Automation System. To avoid misunderstanding later, it is very important that the consultant clearly specify the information from the VAV controller that is to be mapped into the Building Automation System.

During VAV system commissioning, a balancing tool may be used to adjust the calculated airflows to match the measured values. Some VAV systems have a hand-held balancing tool designed for this purpose. The hand-held balancing tool typically connects to a special port on the temperature sensor.

The VAV controller also has a programming tool (typically a software application in a notebook PC) which allows access to all parameters and values in the VAV controller. The notebook PC is equipped with an interface to connect to the special port on the temperature sensor or to the BAS communication bus linking the VAV controllers.

As the balancing tool and the programming tool are only used during system commissioning, they are typically not purchased by the building owner.

Figure 6 - Information typically available from VAV controller.

Available to BAS	Available to Balancing Tool	Available to Programming Tools
<ul style="list-style-type: none"> • Zone temperature 	<ul style="list-style-type: none"> • Parameters / values available to 	<ul style="list-style-type: none"> • All parameters/

- | | | |
|---|---|---------------|
| <ul style="list-style-type: none">• Set-point• Damper position (if AHU optimization is used-see previous article in series)• Calculated airflow (if ventilation control is used-see next article in series) | <ul style="list-style-type: none">• BAS, including damper position and calculated airflow• Flow set-point• "K" factor• Box area• Minimum airflow• Maximum airflo | <p>values</p> |
|---|---|---------------|

Conclusion

VAV controllers have a sophisticated control algorithm to maintain comfort in the space by adjusting the flow of cool air.