



By **Sanjib Seal** Senior Solution Manager, India, Swegon BlueBox, Navi Mumbai

Introduction

A data center is a facility used to house computer systems and associated components such as telecommunications and storage systems. It generally includes redundant or backup power supplies, redundant data communications connections, environmental controls (e.g. air conditioning, fire suppression) and various security devices. All our online activity is delivered through data centers and the more we send emails, watch online video, use social media like Facebook, conduct business online, use Cloud, Big Data, Internet of Things and BYOD, the more data centers grow. Every time we upload a video, share a photo, tweet our location or check bank details, our web device talks to a data center. Rows of servers storing trillions of megabytes of information live in vast, energy-hungry computing complexes that power the web. Data centers are responsible for about 2% of global carbon emissions today and use 80 million megawatt hour of energy annually. As per a study, at the current growth rate and without improvements in energy efficiency, data center will produce 360 megatons CO₂ by 2020.

About the Author

Sanjib Seal is Senior Solution Manager at Swegon BlueBox India. He has been in the HVAC&R industry since 2007 and has a diverse background in application, design, commissioning, new product development and CFD analysis for high tech environments. His experience also includes Green building energy efficiency technologies and analysis of critical application support facilities. He has experience in projects involving chip level liquid cooling and free cooling in India and European markets.

How Heat is Generated in a Data Center

Figure 1 shows a typical break up of energy consumed in a data center (DC).

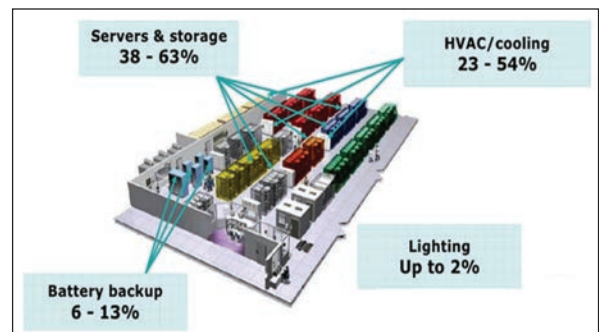

Figure 1: Typical break up of energy use in a data center

At an average, 45% of the heat generated in a data center is to meet the cooling demand: the chiller consumes 33%, humidifier 3% and Computer Room Air Conditioning (CRAC) unit 9%.

The rest of the heat is generated by IT equipment (30%), PDU (5%), UPS (18%), lighting (1%) and switchgear/generator (1%).



Developments in the Data Center Market

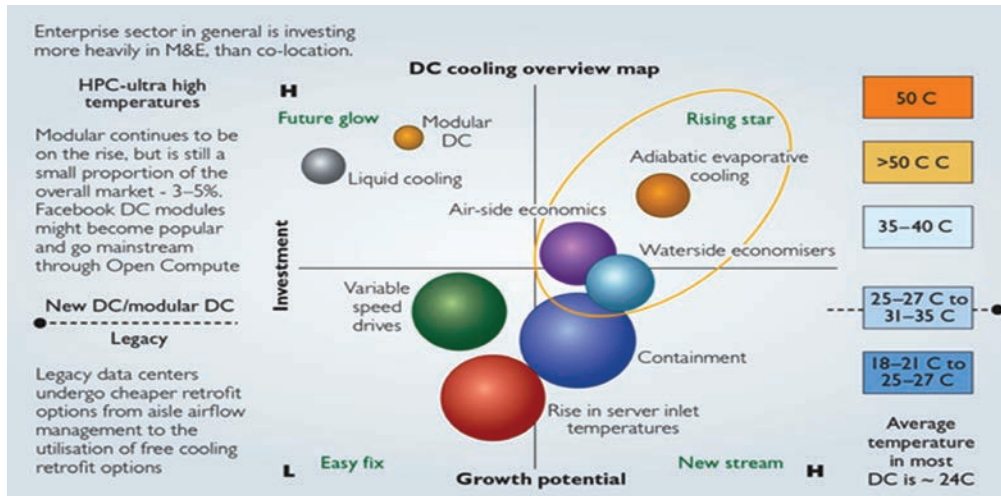

Source: BSRIA Cooling Technologies Report 2015

Reducing Cooling Energy

There are various ways to reduce power consumption for cooling/ventilation to less than 30%:

- Increasing server room temperature
- Increasing cooling equipment efficiency
- Reducing cooling distribution

Right Temperature in a Data Center

The traditional view is that CRAC return air temperature should be 18°C-20°C. Why are such low temperatures recommended?

Legacy data centers used outdated equipment and had reams of paper inside. This demanded strict control of temperature and humidity at low levels. New technologies do not use paper anymore. The maximum acceptable temperature has to be provided by the server vendor.

ASHRAE Technical Committee 9.9-2015 has published the recommended and allowable environmental specifications for IT equipment (Table 1), with a view to achieving energy savings.

It clearly mentions that air inlet to IT equipment is the important specification to meet.

Outlet temperature is not important. The recommended server inlet temperature is 18°C to 27°C; the humidity level is recommended as 41.9°F (5.5°C) dew point to 60% RH and an allowable range of between 20-80% RH. Usually all servers are designed within this range.

Data Center Cooling System Efficiency

There are primarily two types of cooling in a DC:

- Mechanical cooling – all the cooling systems that provide a vapour compression cycle involving a refrigerant (natural or synthetic).

Table 1: ASHRAE recommended and allowable environmental specifications for IT equipment

Class ^a	Equipment Environmental Specifications for Air Cooling						
	Product Operations ^{b,c}					Product Power Off ^d	
	Dry-Bulb Temperature ^{e,g} °C	Humidity Range, Non-Condensing ^{h,i,k,l}	Maximum Dew Point ^k °C	Maximum Elevation ^{e,j,m} m	Maximum Temperature Change ^f in an Hour (°C)	Dry-Bulb Temperature °C	Relative Humidity ^k %
Recommended (Suitable for all 4 classes)							
A1 to A4	18 to 27	-9°C DP to 15°C DP and 60% RH					
Allowable							
A1	15 to 32	-12°C DP & 8% RH to 17°C DP & 80% RH ^k	17	3050	5/20	5 to 45	8 to 80
A2	10 to 35	-12°C DP & 8% RH to 21°C DP & 80% RH ^k	21	3050	5/20	5 to 45	8 to 80
A3	5 to 40	-12°C DP & 8% RH to 24°C DP & 85% RH ^k	24	3050	5/20	5 to 45	8 to 80
A4	5 to 45	-12°C DP & 8% RH to 24°C DP & 90% RH ^k	24	3050	5/20	5 to 45	8 to 80
B	5 to 35	8% to 28°C DP & 80% RH ^k	28	3050	NA	5 to 45	8 to 80
C	5 to 40	8% to 28°C DP & 80% RH ^k	28	3050	NA	5 to 45	8 to 80

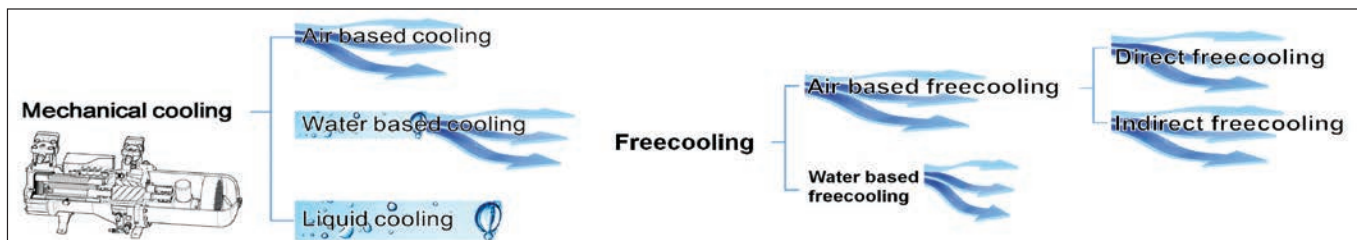

Figure 2: Classification of mechanical and free cooling



- ii. Free cooling – cooling systems that transfer cooling energy from outdoor to indoor without using vapour compression cycle (mechanical power is still used).

Mechanical cooling and free cooling can be further classified as shown in *Figure 2*.

Mechanical Cooling Processes

- Perimeter cooling (room oriented): A mechanical cooling system (or a mix of mechanical cooling and free cooling) is based on the combination of a cooling generator (positioned outside the IT area) and several terminal units (positioned in the IT area). CRAC units are located at the perimeter of the room and use underfloor air distribution or ducting.
- In-row cooling (row oriented): In-row cooling units are located adjacent to the server rack. The cooling coil with supply fans is located adjacent to the server rack. The number of units will depend on the server load density and load distribution. The cool air travel path is minimum.



Figure 3: Perimeter cooling



Figure 4: In-row cooling

A chilled water system is more energy efficient compared to a direct expansion system, particularly in large data centers.

Some of the advanced technologies that can be used in data centers to achieve higher energy efficiency are listed below.

1. Inverter scroll compressor with DC motor – applicable for CRAC units in small data centers, where load density is low. This type of compressor uses a drive to control the compressor motor speed to modulate the cooling capacity. It takes advantages of low lift, better efficiency at part load and soft start to save energy. Inverter DC motors are more efficient compared to inverter AC motors.
2. Inverter screw compressor – applicable for chiller units in larger data centers. This also takes advantage of inverter

technology. A compressor with in-built inverter results in higher efficiency compared to an external variable frequency drive (VFD) mount system.

3. Fans with electronically commuted motor (EC motor) and composite material are widely used in CRACs and chillers for data center applications due to higher energy efficiency and reliability.
4. Primary variable pump with multi-sensor logic is a popular choice for DCs.

Refrigerant

Globally, HFCs – R410A and R134a – are the most common refrigerants used in CRAC/chiller. But HFC use will be limited in future due to their high GWP. We may see volume reduction of these refrigerants in commercial refrigeration by 2022.

To meet the forthcoming changes in regulations, hydrofluoroolefins (HFOs), also known as unsaturated hydrocarbons, are considered to be the most viable platforms, with R1234ze, R1234yf and R1233zd as the main isomers considered to have similar applications in the cooling industry. Currently some chiller OEMs have started using R1234Ze for screw chillers and R1233Zd for centrifugal chillers.

Treated Fresh Air Units

Fresh air needs to be provided in DCs, usually one air change/hour to maintain positive pressure. A DOAS with energy recovery wheel (absorption/hygroscopic) and supply air temperature control is recommended to save energy and control humidity.

Containment Cooling (Aisle Oriented)

Containment means to physically separate hot and cold sides.

Hot aisle/cold aisle data center design involves lining up server racks in alternating rows with cold air intakes facing one way and hot air exhausts facing the other. The rows composed of rack fronts are called cold aisles. Typically, cold aisles face the air conditioner output path. The rows the heated exhaust pours into are called hot aisles. In this process, typically, more air is circulated than required.

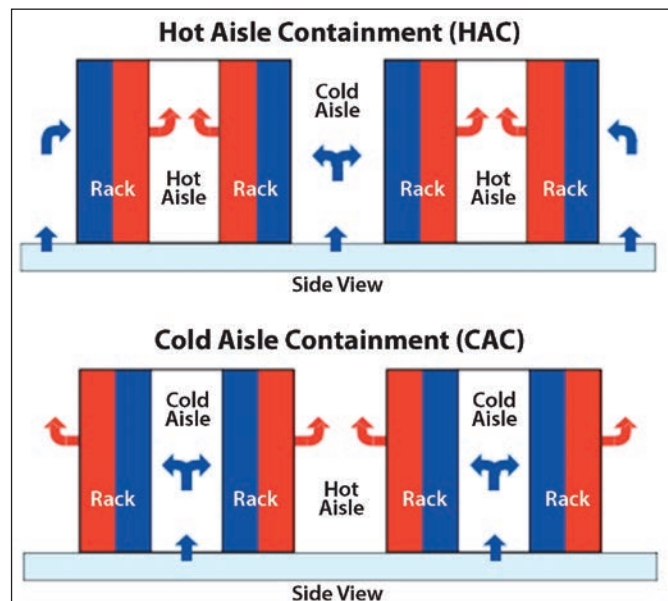

Figure 5: Hot and cold aisle containments



Air mixing and short circuiting lead to low supply temperature and low ΔT .

Containment systems started out as physical barriers that simply separated the hot and cold aisles with vinyl plastic sheeting or Plexiglas covers. Today, vendors offer plenums and other commercial options that combine containment with VFDs to prevent cold air and hot air from mixing.

Both of them suit either perimeter cooling or in-row cooling. Both HAC and CAC have their own advantages:

1. In a contained configuration, the cooling system can be set to higher supply temperature within the recommended ASHRAE guidelines, thereby saving energy and getting higher cooling capacity. This allows increased cold air supply and warmest possible return air to the unit, resulting in higher heat exchanger efficiency. A typical uncontained system uses 7°C water in the cooling coil, resulting in 10°C outlet, whereas in a contained system 18°C water can be used. Compared to a conventional DC, this improves energy efficiency by 25% to 40%.
2. Isolation ensures uniform supply air temperature at server inlet, eliminating hot spots.

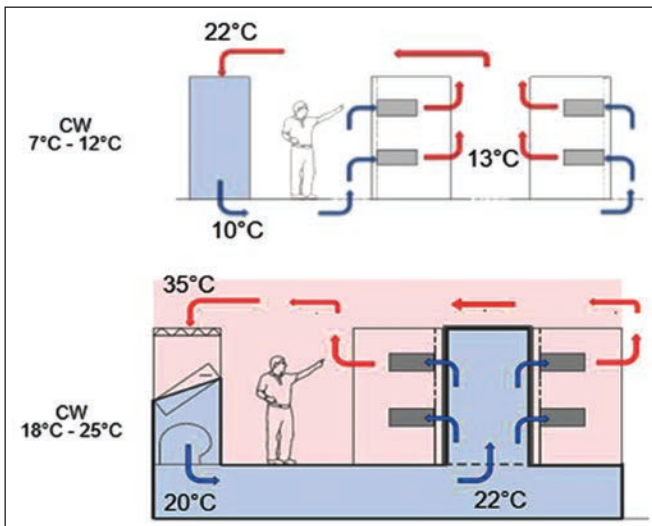

Figure 6: Chilled water and air temperatures in uncontained vs. contained systems

3. Economizer hours will increase due to higher room temperature. In HAC, the return air temperature can be much higher (exceeding 35°C). This maximises the efficiency of cooling units. When HAC is used with perimeter cooling, it is not focused on cooling; hot air ducting leads to higher pressure losses; overhead space is required for ducts; and retrofitting is difficult. When HAC is used with in-row cooling, it is more efficient and no ducts are required. But it is not focused on cooling.

In CAC, the amount of recirculation/hot spots is virtually zero. This guarantees the correct cold air temperature to the servers with the help of constant supply sensor logic. When CAC is used with perimeter cooling, there is higher cooling load compared to HAC; it meets ASHRAE requirements; raised floor is needed; and it is more

retrofit-oriented. When CAC is used with in-row cooling, there is maximum cooling load, higher efficiency and it is more retrofit-oriented.

Direct Free Cooling

In this process, outdoor cold air is directly blown through filters in the data center to control the indoor temperature. Fresh air is continuously introduced indoors.

The Air Side Economizer concept suits, in particular, large enterprise data centers.

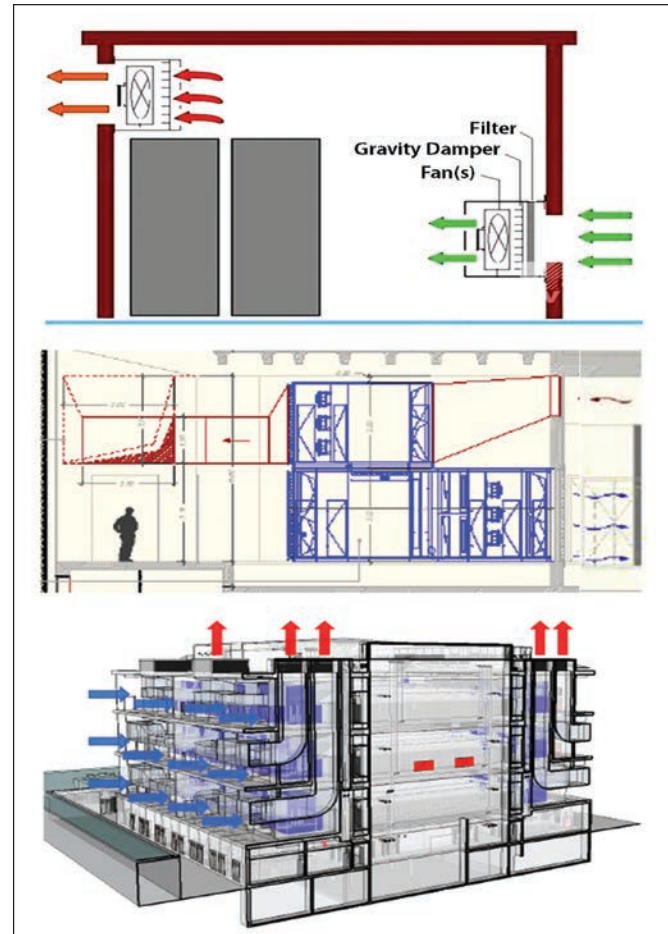

Figure 7: Air side economizer

This concept is applicable where servers are replaced every 2/3 years, space and servers are not intended to be rented and the DC owner has complete control on and responsibility for it. Here, temperature/humidity control, filtration, ventilation and 100% back up cooling are needed.

Direct free cooling has its constraints. The quality of outdoor air used for ventilation, pressurization and cooling remains a source of contaminants. Even clean air requires filtering.

A data center must be kept clean to ISO 14644-1 class B. This requires that:

1. Room air should be continuously filtered with MERV 8/G4/F5.
2. Air entering must conform to MERV 13 / F7.



3. Gaseous contamination should be within ISA 71.04: 2013 with severity level of GI Mild.

In this case, filters reduce the air flow, expend energy to pull the air through them, and require cleaning and replacement, which requires labour. Humidity also has to be controlled. The best locations for free cooling are generally lower-humidity areas. High humidity requires dehumidification, which requires mechanical refrigeration, which is what basically we are trying to reduce with free cooling.

Indirect Air Free Cooling

In this process, outside cold air is used to cool down the recirculated air in the data center without introducing fresh air and maintaining the indoor space isolated. The outside air brings the temperature down indirectly through heat exchangers.

Adiabatic Free Cooling

Another indirect cooling, which is a variation on air-side free cooling, is that in which the air is brought to some sort of a chamber and used along with water evaporation to cool the air. This suits, in particular, medium/large co-location data centers.

These two solutions combine a lot of advantages of direct free cooling with complete flow separation. The efficiency decreases a bit compared to a direct free cooling solution, but it allows a very strict control on the indoor air condition.

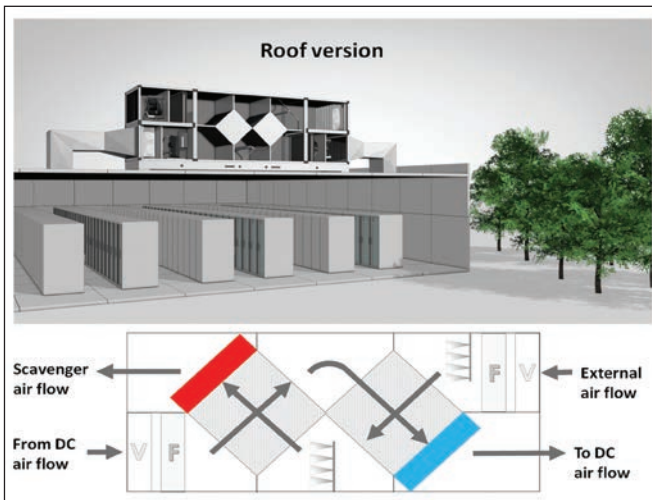

Figure 8: Indirect free cooling

Cool outside air is drawn through a heat recovery unit and immediately exhausted, while internal air is drawn from the room and circulated through the heat recovery unit before being re-introduced to the room. The outside air's cool thermal energy is thus transferred to the internal air via the heat recovery unit without the two streams directly mixing.

By humidifying the outside air prior to entering the heat recovery unit, its temperature is economically reduced and even more low cost cooling is applied to the internal atmosphere. This enhances the capacity of the system and makes it effective even when the outside temperature is warmer than the desired internal room condition.

As the internal air never mixes with outside air, there is a reduced possibility of the internal atmosphere being compromised by external pollutants, so this is an ideal strategy for critical environments.

This solution is applicable where servers are replaced less frequently, space and servers are intended to be rented, no contamination is allowed and customers need a warranty about the safety of their data. A partial back up cooling system is generally needed due to the high efficiency free cooling.

Air Cooled Chiller Free Cooling

The strength of the free cooling units is certainly the control system that allows maximum use to be made of the free resource, consisting of external air, so minimizing the energy used by the compressors. It suits in particular medium/large co-location data centers.

In this process, when the ambient temperature is higher than the temperature of the water and glycol solution returning from the system, all the refrigeration capacity is generated by the compressors.

The free cooling section and relevant fans remain inactive and therefore the operation of the unit is that of a classic compression chiller.

Free cooling starts automatically when the external air temperature is lower than the temperature of the water and glycol solution returning from the system. The free cooling system acts in combination with the mechanical cooling system to ensure full coverage of the heat load.

The solution is partially cooled in the free cooling coils by external air; the remaining refrigeration capacity needed is produced by the chiller section that works in reduced capacity mode. This gives an immediate energy saving that, as the ambient temperature falls, becomes increasingly substantial.

Below a certain external air temperature, the unit operates only in free-cooling mode: cooling of the glycol solution takes place only in the water coils, while the compressors and fans of the chiller section remain switched off.

For even harsher external air temperatures, part of the free cooling fans will be switched off gradually to avoid running the risk of over-cooling the glycol solution.

Indirect Water Free Cooling with Water Side Economizer

Water side free cooling, where a cooling medium such as water or glycol circulates directly through cooling towers or dry coolers rather than the chillers or compressors, suits in particular medium/large data centers, and is useful when no contamination is allowed. A complete back up cooling system is generally needed due to the intrinsic inefficiency of free cooling.

Weighing the pros and cons is a complicated exercise. Water side free cooling is the easiest. Most data centers use chilled water to cool their systems. So it is logical to use water side free cooling because the piping and the cooling towers are already in the plan. That makes the incremental cost relatively small. Power for pumps and cooling towers is still required, of course.

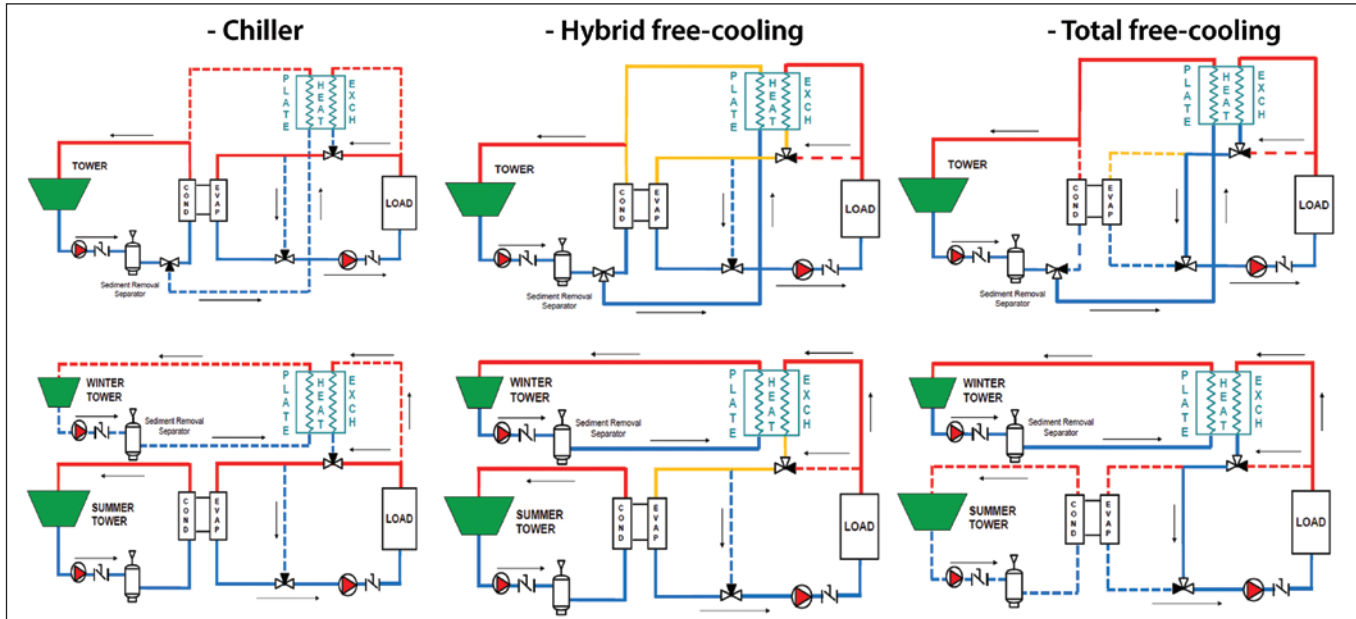

Figure 9: Chiller cooling, hybrid free cooling and total free cooling

The problem is the change-over. No one wants to change from free cooling to mechanical refrigeration often, because short-cycling of compressors is not desirable. Manual change-over is supposedly simple, but can get rather involved. There are many cases where the gain is not worth the effort if the system is not going to be used. Automated controls solve that problem, but they can get complex and need a wide window to ensure that the system does not go changing back and forth between free cooling and mechanical refrigeration.

Waste Heat Reuse

Wasted heat is recirculated to heat the office space and is mixed with outside air in the penthouse to meet the temperature set point and warm the air before it enters the data center.

Waste heat can be used in different ways:

- Chiller cold water is used in DC cooling and by-product hot water is used to meet the cafeteria or building hot water demand.
- Waste heat from the server can be stored directly for hot water demand.

Practically heat reuse-Energy Reuse Effectiveness (ERE) gives more saving than improving the Power Usage Effectiveness (PUE).

Liquid Cooling

Traditional air cooled data centers use chiller and air conditioning systems to gain lower temperature in order to maintain the chip temperature on the motherboard. To resolve the conflict between efficiency and performance in the data center, liquid cooled solutions are starting to be seen more often in modern data centers. Nowadays designs like backdoor water-cooled solutions are seen more often in high efficiency data centers. This can improve the PUE down to 1.2 or lower.

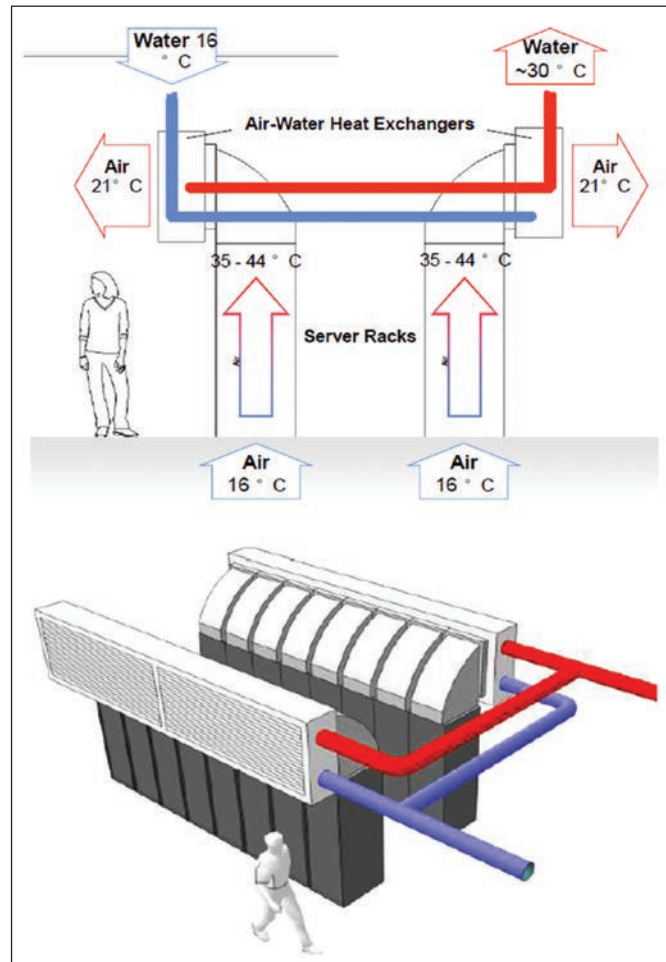

Figure 10: Waste heat reuse



Table 2: AHSRAE liquid cooling guidelines

Liquid Cooling Classes	Typical Infrastructure Design		Facility Supply Water Temp.
	Main Cooling Equipment	Supplemental Cooling Equipment	
W1	Chiller / Cooling Tower	Water-side Economizer (cooling tower or drycooler)	2 – 17°C (36 – 63°F)
W2			2 – 27°C (36 – 81°F)
W3	Cooling Tower	Chiller	2 – 32°C (36 – 90°F)
W4	Water-side Economizer (cooling tower or drycooler)	N/A	2 – 45°C (36 – 113°F)
W5	Building Heating System	Cooling Tower	>45°C (>113°F)

Three types of liquid cooling systems are available:

- Indirect Liquid Cooling – Air is passed through servers and then through a rear door or in-row water heat exchanger.
- Direct Liquid Cooling – Liquid is taken direct to some components. CPU board is air cooled but air is cooled by heat exchangers and fans in the adjacent racks.
- Total Liquid Cooling – All components are cooled directly by liquid. Air side losses are minimized. In this process there will be no fan and no outside air. Liquid mineral oil or 3M Novec is generally used in this process.

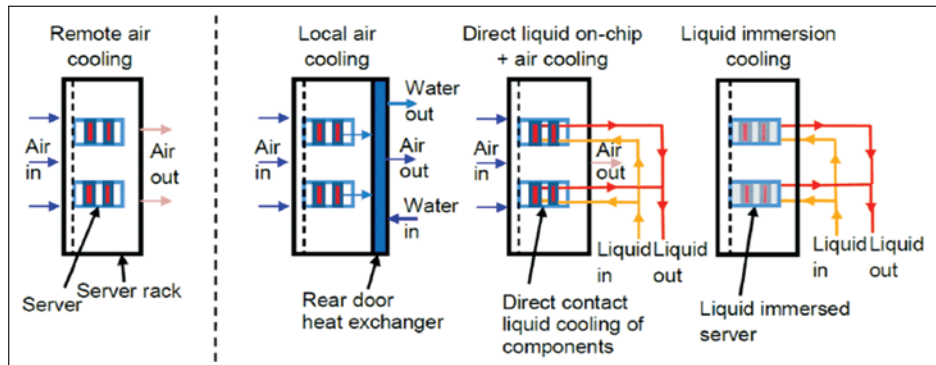

Figure 11: Liquid cooling

Both the fluids have dielectric properties. Electronics can be submerged in the fluid (not moving parts). In this process heat is transported by circulation.

The advantages of liquid cooling are:

1. Low energy is used for cooling (liquid pump).
2. Efficient cooling – CPU runs faster.
3. Higher liquid temperature than going via air, hence higher free cooling hours and possibility of heat reuse.

There are some limitations of liquid cooling:

1. Corrosion and bacteria in hot water – filters and devices required to take away air, chemicals and black.
2. Shortens life time of DC equipment.
3. Lack of standards – different temperatures and pressures are used; different requirements of clean water.

Conclusion

Data centers are amongst the most energy consuming facilities with rapidly growing and updated technologies. Attempting to use the same rules, processes, and methods for data centers that were used for old facilities can result in lost energy saving opportunities and reduced customer satisfaction. It is important to understand new technologies, servers and new building construction implementation programs to recognize some of the unique qualities that set data centers apart from earlier facilities, and to modify or design new policies and procedures respectively. Increased awareness and employing a few of the recommended modifications listed in this article along with the existing approaches can save energy.

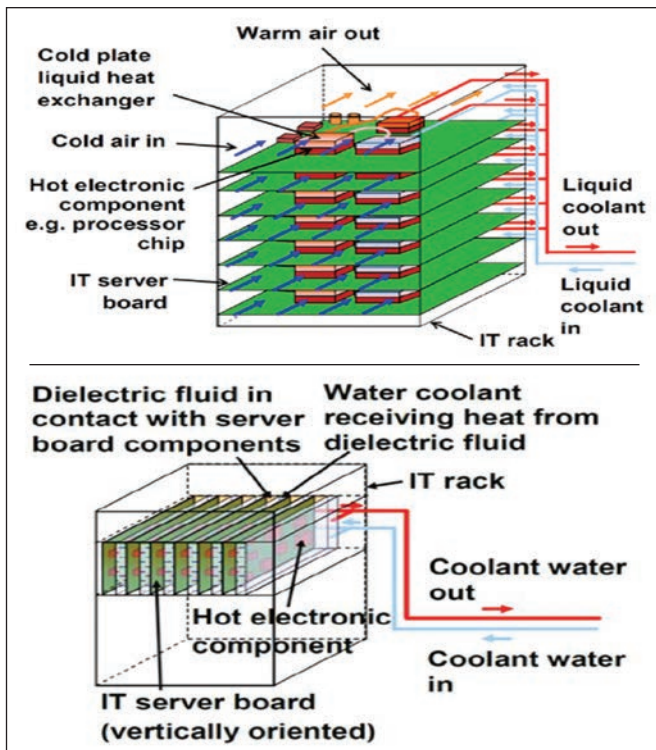

Figure 12: Total liquid cooling