

## Best of ASHRAE Journal

"All-Variable Speed Centrifugal Chiller Plants" was awarded the 2001 Journal Paper of the Year Award. Author Tom Hartman says the topic is still relevant today. The article originally ran in the September 2001 issue.

©ASHRAE [www.ashrae.org](http://www.ashrae.org). Used with permission from ASHRAE Journal. This article may not be copied nor distributed in either paper or digital form without ASHRAE's permission. For more information about ASHRAE, visit [www.ashrae.org](http://www.ashrae.org).

# All-Variable Speed Centrifugal Chiller Plants

By **Thomas Hartman**

P.E., Member ASHRAE

*Very often selection programs find variable speed centrifugal chillers to be less cost effective than constant speed chillers. This has made uncertain the future of variable speed in centrifugal chiller plants. However, plants with variable speed chillers can operate much more efficiently than constant speed plants, but only if operating strategies are incorporated that are tailored specifically to these chillers' unique performance characteristics.*

## Introduction

This article explains at the applications level how variable speed centrifugal chillers can be applied and operated more effectively to enhance their performance in comfort conditioning chiller plant applications. Furthermore, this article shows that all-variable speed chiller plants (plants in which chillers, condenser pumps and tower fans all use variable speed drives) can improve plant efficiency significantly without adding capital costs to the chiller plant design.

## Performance Characteristics

Variable speed chillers often are not included in chiller plant designs because variable speed chillers are still seen as an add-on to an otherwise constant speed chiller plant. When variable speed is used, it is often applied only to one chiller in the plant. Otherwise, the plant usually operates the same as a conventional constant speed plant. However, conventional chiller sequencing strategies do not extract the full potential of variable speed chillers because of differences in performance characteristics between variable speed and constant speed chillers.

Figure 1 compares the performance curves of a typical constant speed centrifugal chiller with that of a variable speed centrifugal chiller with the same mechanical components at various loads and entering condenser water temperatures. The performance curves in Figure 1 show the wire-to-water performance for the two chillers. This notation means that the performance in kW/ton at each point includes all mechanical, motor and variable speed drive losses. The performance curves in Figure 1 also assume a constant chilled water supply temperature at all operating conditions.

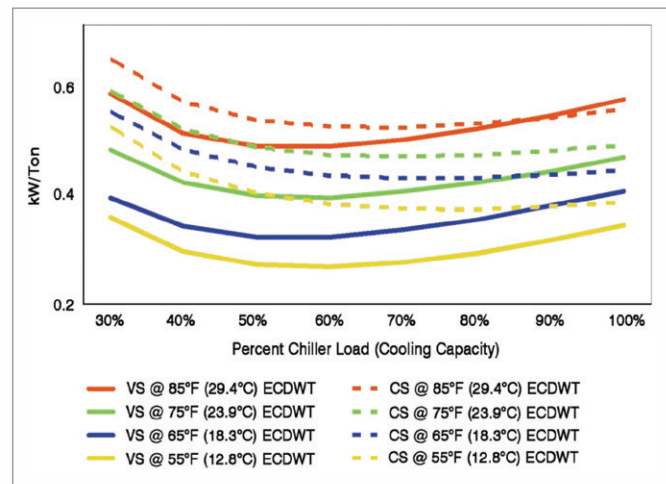

Figure 1: Performance comparison of constant and variable speed centrifugal chiller.

Figure 1 illustrates two important performance differences between variable and constant speed centrifugal chillers:

1. When the entering condenser water temperature is fixed, constant speed centrifugal chillers have a relatively flat operating efficiency over the 50% to 100% load range while variable speed chillers see an improving efficiency (lower kW/ton) as the load drops below 100%.

## About the Author

Thomas Hartman, P.E., is owner of The Hartman Co., Georgetown, Texas. He is a member of ASHRAE SSPC 55.

- The efficiency of a variable speed chiller is more positively affected by reductions in the condenser water temperature than a constant speed chiller.

These two performance differences make imperative a reconsideration of how a plant can be operated most effectively when variable speed centrifugal chillers are incorporated in the plant design. The differences can also help explain how it is possible to configure variable speed plants that provide improved efficiency but have about the same installed cost as constant speed plants. This cost issue will be discussed later in this article.

### Chiller Operation

Engineers and plant operators are most familiar with constant speed chiller operation. Because constant speed chillers have a relatively flat performance curve across a range of loading conditions (*Figure 1*), the focus of constant speed chiller plant operations has been to minimize the amount of on-line equipment. This permits chillers to operate as close as possible to their full capacity to reduce the percent of parasitic load from condenser water pumps and tower fans that are usually sequenced with chillers. However, *Figure 1* also shows that variable speed chillers operate most efficiently well below full load. The efficiency improvement can be substantial.

To determine how to sequence variable speed chillers for their most efficient operation, a new chiller performance parameter has been developed called the “natural curve”<sup>1</sup> of the chiller. *Figure 2* illustrates the natural curve concept. Like *Figure 1*, the performance curves in *Figure 2* assume a constant chilled water temperature at all loads. However, in *Figure 2* the performance curves are for equal leaving condenser water temperature instead of entering condenser water temperature. The use of leaving condenser water temperature (like the use of chilled water supply temperature) is a more useful concept in rating chillers because it compensates for variations in condenser water flow.

For example, if condenser water flow is varied, the performance of the chiller will remain in accordance with *Figure 2* so long as the leaving condenser water temperature is the parameter monitored to determine performance. If the flow is reduced, a lower entering

condenser water temperature must be provided to maintain the same leaving condenser water temperature. This results in a higher log mean temperature difference between the condensing water and the refrigerant in the condenser that offsets the loss in water-to-tube conductance caused by the lower flow rate.

Conversely, at higher flows a lower temperature difference offsets the increase in the water-to-tube conductance due to the higher flow rate. This characteristic has been shown to hold for chiller evaporators over ranges of flow.<sup>2</sup> Though the direction of heat flow is opposite in a chiller condenser, the characteristics of the heat transfer are essentially the same, and rating chiller efficiency based on leaving condenser water temperature eliminates the need to make adjustments for changes in the rate of water flow through the condenser over a range of possible flow rates.

As shown in *Figure 2*, the natural curve of a variable speed chiller when operating with a fixed chilled water supply temperature is a simple concept. It is the locus of points of highest chiller operating efficiency at various condenser water temperature and load conditions. Notice that the best efficiency (lowest kW/ton) for the variable speed chiller when the leaving condenser water temperature is 85°F (29°C) is achieved at about 63% load. This is the point on the natural curve for that condensing water temperature. The natural curve is developed by connecting the points of highest efficiency for each condensing water temperature.

A similar natural curve can be constructed for applications where chilled water supply temperature is variable. Because the natural curve of a chiller represents the highest operating efficiency curve of the chiller, it is clear that for maximum chiller operating efficiency, chillers should be sequenced to operate as closely as possible to their natural curves. *Figure 2* shows that the natural curve, and therefore, the loading at which optimum operating efficiency is achieved for a variable speed chiller, is not at or near its full capacity at any condenser water temperature condition.

*Figure 2* is typical for many variable speed chillers. Therefore, to operate variable speed chillers most efficiently, the sequencing methodology needs to be different than that normally employed for constant speed chillers. This is one reason why variable speed chillers do not achieve optimum performance when mixed with, or operated the same as, constant speed chillers in a chiller plant.

### Condenser Pumps and Cooling Towers

Another way to improve variable speed chiller efficiency is to take advantage of the fact that the performance of variable speed chillers is more sensitive to reductions in condenser water temperatures (*Figure 1*). A significant amount of research and development has been done on tower optimization strategies.<sup>3,4,5</sup> However, there has not been a strong emphasis on operating cooling tower fans and condenser pumps more effectively in multi-tower plants. This is because constant speed chillers are not as significantly affected by reductions in condenser water temperatures as are variable speed chillers.

Currently, most chiller plant operating strategies seek to keep the water flow rate through condenser bundles constant. Before

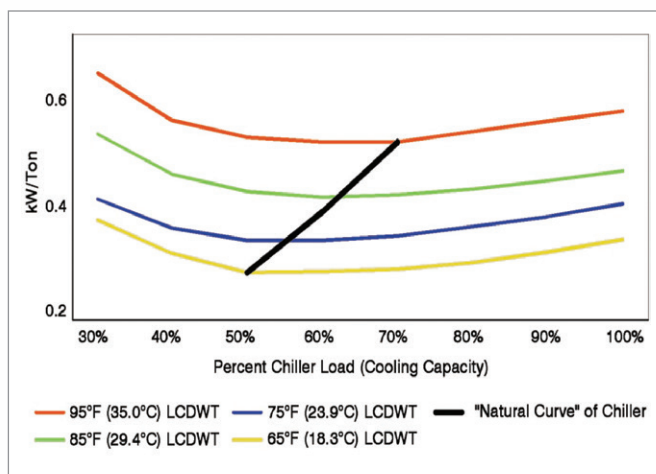

Figure 2: The “natural curve” of a variable centrifugal speed chiller.

network-based digital controls were available, constant condenser water flow was desired because chiller controls were reactive, and changes in condenser conditions could affect the stability of the stand-alone chilled water temperature control provided with each chiller.

The operation of tower fans varies from project to project. Many chiller plants operate tower fans to provide a specific tower leaving water temperature. When variable speed chillers are applied, the efficiency improvements that can accrue from lower condensing water temperatures have led some to recommend a low leaving tower water temperature setpoint as an optimization strategy. Others adjust the leaving tower water setpoint based on outdoor wet-bulb temperature or other criteria. However, nearly all tower fan and condenser pumping strategies shed condenser pumps and tower fans, usually in parallel with the shedding of chillers, as the load falls. When variable speed chillers are used, these existing tower and pump control strategies are not effective because they fail to optimize the efficiency of the heat rejection components at part loads in multi-tower plants.

Shedding towers as the cooling load falls due to reduced ambient temperatures leads to higher tower water approach temperatures. The relationship between plant load, wet-bulb temperature and tower approach for a chiller plant is shown in *Figure 3*. The data in *Figure 3* are based on actual crossflow tower performance for a typical chiller plant located in the Detroit area serving a comfort conditioning application. The plant is comprised of three chillers and towers with constant speed condenser pumps and tower fans that operate according to a leaving tower water setpoint when the chiller served by each tower is on line.

*Figure 3* assumes the condenser pumps account for 60% of the total heat rejection power and the tower fans the remaining 40%. The tower is selected for 3 gpm/ton (0.05 mL/J) and an entering water temperature of 95°F (35°C) at design conditions. If the plant is operated conventionally, chiller and tower sets are normally shed as the load decreases. At 100% load, all three towers and chillers will be on line. At two-thirds load, one chiller/tower set will be shut down and the load will be carried by two towers and chillers. At one-third load, a single tower/ chiller

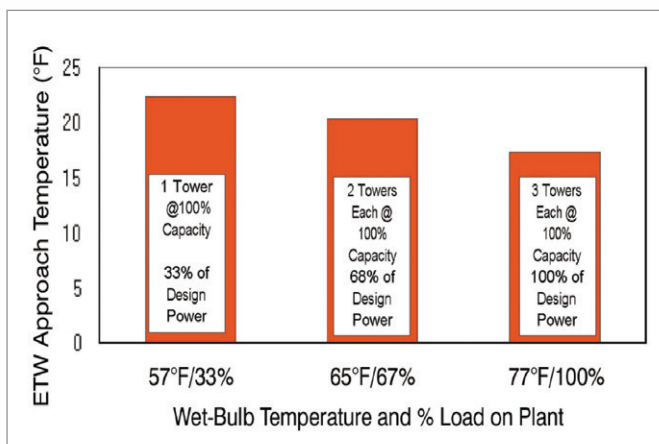

Figure 3: Effect of wet bulb on cooling tower approach.

operates. The expected wet-bulb temperatures shown at each of the three load points in *Figure 3* reflect the Detroit area climate. While the design maximum wet-bulb temperatures vary, the rate of decrease in wet-bulb temperature with cooling load is typical of much of the interior United States and Canada for comfort cooling applications.

An operation strategy that involves maintaining a low leaving tower water setpoint will result in continuous full speed tower fan operation at each of the load conditions (*Figure 3*). The resulting approach temperature at each load point is shown based on entering tower water temperature (leaving condenser water temperature). By adding the approach temperatures in the figure to the wet-bulb temperature for each load point, the net effect on chiller head at each load point can be determined. With this chiller and tower sequencing strategy, the tower approach temperature rises as the chiller plant load and outdoor wet bulb fall. The rising approach diminishes some of the potential benefits of variable speed chiller applications because variable speed chillers benefit significantly from reduced condensing temperature.

When the chillers and pumps are operated by effective network control, the need for constant condenser water flow is eliminated because the network control can provide proactive control where systems and components react to changes in a coordinated fashion. With network-based digital controls, flow in both the evaporator and condenser of a centrifugal chiller can be varied over significant ranges, and the chiller can continue stable and effective operation.

If the chiller plant uses an operating strategy where towers remain on line but condenser pumps and tower fans are slowed as the cooling load falls, significant reductions in condensing temperature can be achieved using the same or less power as the tower shedding strategy. *Figure 4* shows the effect on leaving chiller condenser water temperature for the tower staging strategy of *Figure 3*. *Figure 4* also shows a strategy where condenser pumps and tower fans are slowed rather than shed, such that the total input power required by the pumps and fans is exactly the same at each of the three points for both strategies. The power for both strategies includes all motor and variable frequency drive losses.

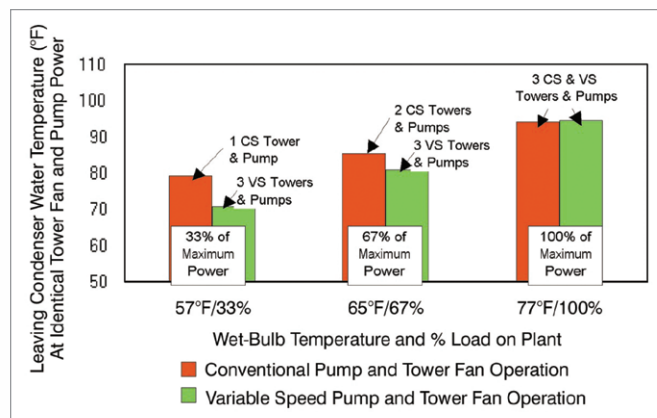

Figure 4: Comparison of conventional and variable speed condenser pump and tower fan operation.

continued on page 58

continued from page 56

As shown in *Figure 4*, the leaving condenser water temperatures that can be achieved with the same input energy, but by slowing the pumps and fans in a coordinated fashion, are lower than by shutting towers down as the load falls. Because *Figure 4* compares leaving condenser water temperatures, the difference between the two strategies provides an accurate comparison of the effect on chiller efficiency performance regardless of any differences in water flow rates. The flow through the cooling towers varies when pumps slow and towers remain on line. To perform as shown in *Figure 4*, the distribution system for each tower must be designed to accommodate the expected range of flows effectively.

*Figure 4* shows that slowing condenser pumps and tower fans and keeping towers on line results in lower chiller condenser temperatures compared to shedding constant speed condenser pumps and towers as the load falls when the total power use is the same for both. Other methods of condenser pump and tower fan control have been considered. Some involve operating all pumps and fans at full speed, while others sequence constant speed pumps and variable speed towers at different load points or temperature setpoints. However, using all-variable speed equipment on the heat rejection side, which is designed to operate with speed control based on load conditions of the variable speed chiller(s) served, results in the highest overall plant performance at part load conditions.<sup>6</sup>

### All-Variable Speed Chiller Plants

A strong tie exists between the operation of the chillers and the heat rejection systems. Several rules concerning the application of variable speed chillers have been derived from such analyses of variable speed plants. These rules are:

1. When variable speed chillers are used, optimum performance and simplicity of operation is achieved when all chillers in the plant are variable speed and have identical performance characteristics.
2. To concurrently achieve the benefits of reduced condensing temperatures and low condenser pump/tower fan power consumption, condenser pumps and tower fans should also use variable speed, making the plant an all-variable speed chiller plant.
3. The focus must be on operating chillers at equal loading and as near as possible to their natural curves, and also on coordinating chiller, condenser pump, and tower fan power to minimize the overall plant power consumption at each load condition. Such coordination is most simply achieved by controlling pump and fan speed directly from percent of maximum input chiller power rather than to meet specific tower or condenser water temperature setpoints.

Operating an all-variable speed chiller plant that consists of variable speed chillers, condenser pumps and tower fans at less than full capacity conditions leads to the greatest operating efficiency. However, there are limits to the amount of load reduction that can be accommodated by slowing the equipment. In *Figure 2*, variable speed chiller efficiency improves as load is reduced to a peak efficiency point (the chiller natural curve), then

falls. The same is true for the heat rejection equipment, but the point of peak efficiency is usually not the same for both systems.

An easy-to-apply technique has been developed using the natural curve to establish the sequencing strategy for variable speed chillers, and coordinating variable speed operation of condenser pumps and tower fans with chiller input loading. The technique operates all plant equipment as close as possible to the curve of highest operating efficiency. The natural curve chiller sequencing and power-based speed control coordination described herein are patented technologies. An inexpensive site license is required for their application.

### Energy Use of All-Variable Speed Chiller Plants

The energy efficiency improvement that can be expected by implementing an all-variable speed chiller plant in place of a conventional constant speed chiller plant depends on the exact design and application in which it is used. It also depends on the climate where the plant is located. *Figure 5* contains a chart showing the comparison of average annual kW/ton for centrifugal chiller plants of various equipment and vintages. Generally, optimized all-variable speed chiller plants can be expected to operate at an average annual kW/ton of between slightly less than 0.5 and 0.7 depending on the application and nominal equipment efficiency. Simulations and analyses based on 15 representative worldwide climate applications show that the annual energy use for all-variable speed chiller plants that are operated with natural curve sequencing and power-based speed optimizing controls will be on average 28% lower than fully optimized conventional constant speed chiller plants with equipment of the same nominal efficiency at peak load conditions.<sup>6</sup>

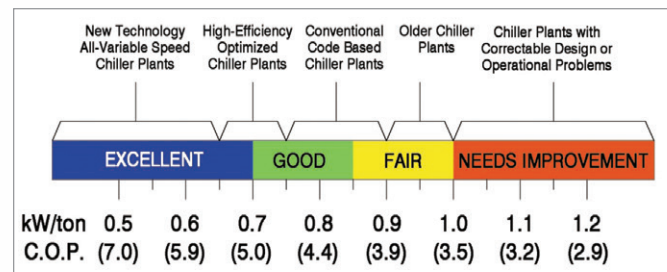

*Figure 5: Average annual chiller plant efficiency in kW/ton (COP). Input energy includes chillers, condenser pumps and tower fans, based on electrically driven centrifugal chiller plants in comfort conditioning applications with 42°F (5.6°C) nominal chilled water supply temperature and open cooling towers sized for 85°F (29.4°C) maximum entering condenser water temperature. Local climate adjustment for North America climates is ±0.05 kW/ton.*

### Comparing First Costs

Usually, it is assumed that there will be a cost premium to construct an all-variable speed chiller plant and that the premium is the cost of the variable speed drives less the cost of the across-the-line starters for the chillers, pumps and fans. However, it becomes evident that in many applications constructing an all-variable speed chiller plant in place of a constant speed plant of the same size and nominal efficiency costs about the same. Consider the chiller performance curves in *Figure 1*. The efficiency of variable speed chillers increases as the load falls. If the chiller plant is designed with

continued on page 60

continued from page 58

a peak capacity larger than the peak load it serves to provide some measure of failure protection, then at peak load conditions, chillers and towers will not operate at full capacity.

In Figure 1, below about 90% load a variable speed chiller of the same nominal efficiency as a constant speed chiller operates more efficiently. When the heat rejection equipment is also considered, the difference increases dramatically. Although it varies among chiller manufacturers, generally one can assume that a variable speed chiller with a wire-to-water nominal full load operating kW/ton of about 0.06 kW/ton higher than a similar constant speed chiller will be similar in cost.

Below about 80% loading, an all-variable speed chiller plant configuration incorporating that variable speed chiller with a higher nominal kW/ton will begin to operate more efficiently than a conventional plant with the more efficient constant speed chiller that has the same initial cost. This means that when chiller plants are sized with a 20% or greater margin of excess capacity, the operating efficiency of an all-variable speed chiller plant incorporating equipment of about the same cost will operate more efficiently even at peak load conditions than a conventional constant speed plant, which loses efficiency when the equipment is oversized.<sup>7</sup>

Anytime a chiller plant is oversized for failure or standby protection the nominal efficiency of the chiller plant should be based on the actual peak load served by the plant rather than the total capacity of the plant. Doing so reduces the nominal full load efficiency requirements of variable speed plant components and therefore lowers their cost. This cost reduction, along with further reductions from effective network control connections<sup>8</sup> offsets the extra cost for the variable speed drives and allows all-variable speed chiller plants to provide substantial annual energy savings while costing about the same to implement as an optimized constant speed alternative of the same capacity. However, designers are cautioned to ensure their equipment selections meet applicable efficiency codes that may be based on full load nominal chiller efficiency.

In the long term, all-variable speed chiller plant applications open up new areas of equipment efficiency improvement opportunities. Many available variable speed chillers have not been designed specifically for variable speed operation. Rather, variable speed drives are simply added to chillers designed for constant speed applications. Chiller manufacturers that want to offer chillers specifically for all-variable speed chiller plants have an opportunity to develop chillers with operating efficiencies at low load conditions that are much higher than today's chillers. At the same time, a substantial opportunity exists to achieve cost savings by configuring chillers only for all-variable speed plant applications.

Chillers suitable for all-variable speed chiller plants can be simpler, more modular and integrated, and supplied in fewer sizes and configurations than required to meet the constant speed chiller market. In small chiller plants, costs can be reduced by using single chillers that fit very well into the load profiles of many plants. In larger multi-chiller plants, designs can be developed that use simple variable speed chillers without prerotational vanes.

### Designing, Commissioning and Operating

All-variable speed chiller plants are configured much the same as constant speed chiller plants. As with conventional plants, chilled water and condenser circuits can use common headers or can dedicate pumps and towers to individual chillers depending on owner preferences, distances, and other considerations. All-variable speed plants generally do benefit when all chillers are selected to be the same size and have identical performance characteristics. It is easier to configure and develop effective controls when chillers are identical. Furthermore, because variable speed chillers operate most efficiently at part load, there usually is not a compelling reason for varying the size of the chillers in a plant. However an all-variable speed chiller plant is configured, maximum and minimum flows and operating temperatures need to adhere to manufacturers' published limits as with any chiller application.

The additional control sequences required to operate an all-variable speed chiller plant effectively with natural curve sequencing and power-based speed control are not difficult to implement. When compared to some optimized constant speed plant control sequences, such all-variable speed plant sequences often are simpler. Outdoor dry-bulb or wet-bulb or tower water temperature controls are not essential to the operation of all-variable speed chiller plants serving most comfort cooling applications.

Consider a typical three-chiller plant schematic as shown in Figure 6. Although plant optimization technologies should

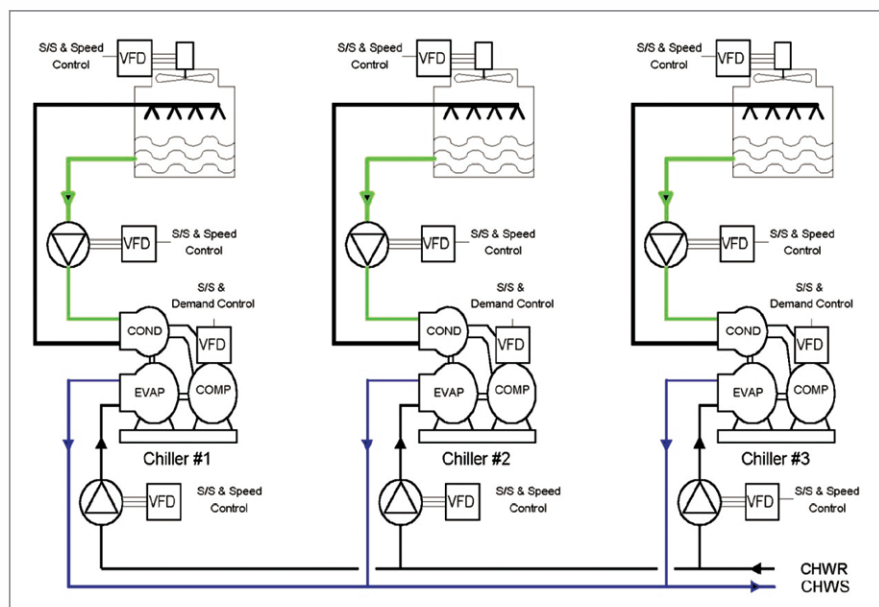

Figure 6: All-variable speed chiller plant.

continued on page 62

continued from page 60

include the distribution system, to simplify this discussion, consider that the speed and loading of the on-line chillers is modulated to meet a specific chilled water supply temperature setpoint. Aside from coordinating the operation of all on-line chillers to achieve equal loading, the operational requirements that are unique to an all-variable speed plant of this configuration fit two basic categories:

1. Sequences for chiller/tower/pump sets such that chillers operate as close as possible to their natural curves.
2. Sequences that optimize the speed of the condenser pumps and tower fans for the chiller tower sets that are operating.

All other control sequences will be essentially the same as those in a constant speed chiller plant of the same configuration. Using the natural curve method of chiller sequencing requires the plant controller to determine at all times where chillers are operating in respect to their natural curve and whether the chillers would operate closer to their natural curve if a chiller were added or subtracted from the on-line chillers.

Generalized algorithms have been developed for estimating the current operating point by measuring the chiller kW and the leaving condenser and evaporator water temperatures. (If plant control is to be accomplished directly by the chiller control panel, it is usually desirable to employ refrigerant temperatures or pressures instead of water temperature, and a control algorithm developed specifically for the chiller to improve sequencing precision.) Formulas have been developed to determine the operating point of a variable speed chiller from input power and leaving chilled water and condenser temperatures. An example is provided below that works well to calculate the current capacity of some chillers from power input, condensing, and chilled water temperatures:

$$Q = C1 \times (CPF)^{C2} \times (DDT/ADT)^{C3-1} - 1$$

Where

$Q$  is the fraction of the design maximum capacity (output) of each on-line chiller.

$CPF$  is the fraction of maximum power currently drawn by each on-line chiller.

$DDT$  is the "Design Delta  $T$ ," the difference between the design leaving condenser water temperature and the design leaving chilled water temperature.

$ADT$  is the "Actual Delta  $T$ ," the current actual difference between the leaving condenser water temperature and the leaving chilled water temperature.

$C1 - C3$  are constants whose values are determined by the performance characteristics of the chillers employed in the plant. These values are determined from the performance data supplied by the manufacturer.

Similarly, the natural curve capacity of a chiller can be approximated for many chillers as a function of the current operating capacity and the difference in condenser and chilled water temperatures compared to the design difference of those temperatures, or:

$$QNC = f(DDT, ADT)$$

For some chillers such as shown in *Figure 2*, this can be approximated as a simple linear function in the form:

$$QNC = C4 \times ADT + C5$$

Where

$QNC$  is the fraction of the design maximum capacity at which the chiller will be operating on its natural curve at the current cooler and condenser conditions.

$C4 - C5$  are constants whose values are determined by the performance characteristics of the chillers.

With the previous calculations, a chiller should be added anytime the operation of the plant will be closer to the natural curve of the operating chillers with an additional chiller on line. Therefore, the general equation for adding a chiller is:

$$\text{IF } |Q - QNC| > |Q \times n / (n + 1) - QNC| \text{ THEN ADD A CHILLER}$$

Similarly, a chiller should be shed if the plant will operate closer to the natural curve with one less chiller on line. The general equation for shedding a chiller is:

$$\text{IF } |Q - QNC| < |Q \times n / (n - 1) - QNC| \text{ THEN SHED A CHILLER}$$

Where

$n$  is the number of chillers on line. (If chillers are not sized identically then  $n$  is the number of chilling units on line.)

Some chiller operation features should be used to adjust these general formulas in practice. For example, chiller performance curves are generally more gradual at operating points above the natural curve than below the natural curve. So, it is generally not desirable to operate a variable speed chiller below its natural curve. This further simplifies the algorithm used to add chillers. Also, looking at the chiller and heat rejection performance together may require a small adjustment in the overall natural curve point at which chillers are sequenced. Once such characteristics are determined, they can be easily used by adjusting or adding to the general sequencing formulas.

The second unique element of an optimum all-variable speed chiller plant operations sequence is to optimize the operation of condenser pumps and tower fans based on the power draw of the chiller served. Optimum overall chiller plant performance is achieved when the rate of plant marginal capacity versus marginal power use is the same for each element of the system. I have named this the "equal marginal performance principle." Using this principle, a generalized formula for determining the speed of the condenser pump and tower fan that serves each on-line chiller has been derived that works well for many comfort cooling chiller applications:

$$RPM = \left[ \frac{(CPF)^{C5} - C6}{(1 - C6)} \right]^{0.25}$$

Where

$RPM$  is the fraction of maximum speed of the pump or tower fan.

$CPF$  is the fraction of maximum power currently drawn by the chiller served by the pump or fan.

$C5$  is a constant whose value depends on the relative sizing (design maximum capacity) of the condenser pump or tower fan. (Generally with a 3 gpm/ton (0.05 mL/J) design maximum

continued on page 64

*continued from page 62*

condenser flow and a tower with a 8°F to 12°F (4°C to 7°C) tower approach, the value of C5 is 1.0 for pumps and fans. If smaller equipment is selected, the value of C5 can be approximated as the fraction of design criteria applied. For example, a 2 gpm/ton (0.04 mL/J) design maximum condenser flow design would use a 0.67 (2/3) exponent for the pump speed control algorithm). If an oversized pump or tower fan is used, C5 will be greater than 1.0. C6 is the fraction of maximum power that the pump or fan draws at 20% speed.

The "equal marginal performance" method of coordinating the heat rejection equipment in an all-variable speed chiller plant does not use tower or condenser water temperature setpoint controls.

The previous general form algorithms are used in the sequence of operations to stage chillers and control the speed of pumps and fans for all-variable speed plants. They are not usually difficult to establish and apply. In addition to these algorithms, certain limiting functions may be used so that condenser pump speed does not drop below a specified minimum. This ensures condenser water flow remains within recommended limits to prevent excessive fouling.

Furthermore, added limits on the condenser water temperature may be helpful to ensure the condensing water temperature remains within prescribed manufacturer's limits at all times. Such limits can be easily added to the sequence of operations and are effective in providing smooth automatic operation during chiller start-up. Limits also provide thresholds for alerting operations staff to potential equipment malfunctions if they occur during plant operation. Natural curve sequencing and power-based speed control can be applied to virtually any type of chiller or compression based cooling equipment including air-cooled chillers and unitary equipment.

Ensuring the achievement of energy performance objectives in an all-variable speed chiller plant design requires a particular focus on how the chillers are procured, commissioned and operated. Procedures have been developed and published<sup>6</sup> that place a strong focus on the following elements crucial to success in any chiller plant. These following elements are especially important when the design involves an all-variable speed chiller plant:

1. A procurement process that requires chiller vendors to certify in their bids or proposals the wire-to-water chiller performance criteria over a range of conditions without credit for ARI-allowed tolerances.
2. A factory performance testing regimen that requires the chiller manufacturer to demonstrate via factory testing that at least one of the chillers (when all chillers are identical) meets the guaranteed chiller performance criteria provided in their bid, and a means for remedy if such performance criteria is not met in the tests.
3. A simple on-site commissioning plan that verifies the minimum and maximum speeds and flow rates of the chiller plant equipment and also verifies the equipment is sequenced and operates correctly.

4. An ongoing on-site performance verification system that provides real-time and accumulated chiller plant kW/ton or COP information to the plant operations staff to ensure that the energy performance of the plant is maintained in the long term.

Employing such an organized and accountable approach to implementing an all-variable speed chiller plant will go a long way toward ensuring it will perform as expected and result in significant annual energy use savings throughout its lifetime.

### Summary and Conclusion

New, all-variable speed chiller plant operating strategies have been developed that are based on the specific performance characteristics of variable speed chillers and the variable flow characteristics of condenser pumps and cooling towers. Substantial annual energy use reductions can be expected from optimized all-variable speed centrifugal chiller plants compared to constant speed chiller plants with the same first cost.

All-variable speed technologies also can be applied to unitary cooling system products with similar improvements in annual energy use. Because it is estimated that cooling systems account for more than 20% of the electrical power generated in the U.S.,<sup>10</sup> this potential reduction in energy, which can be achieved without a first cost premium in many cases, makes the widespread implementation of all-variable speed cooling technologies both desirable and attainable. Implementation of optimized variable speed cooling offers to be an important element in bridging the gap that is developing between electrical generation and energy usage in areas of North America.

### References

- 1) The Hartman Company. 2001. The Hartman LOOP Chiller Plant Design and Operating Technologies: Frequently Asked Questions, March.
- 2) Redden, G.H. 1996. "Effect of variable flow on centrifugal chiller performance." ASHRAE Transactions 102(2).
- 3) Braun, J.E., G.T. Diderrich. 1990. "Near optimal control of cooling towers for chilled-water systems." ASHRAE Transactions 96(2).
- 4) Cascia, M.A. 2000. "Implementation of a near-optimal global setpoint control method in a DDC controller." ASHRAE Transactions.
- 5) Schwedler, M. 1998. "Take it to the limit...or just halfway?" ASHRAE Journal July.
- 6) Hartman, T.B. 1999. "'LOOP' Chiller plant dramatically lowers chilled water costs." Renewable and Advanced Energy Systems for the 21st Century, Lahaina, Hawaii.
- 7) Guven, H., J. Flynn. 1992. "Commissioning TES systems." Heating, Piping, Air Conditioning Magazine January.
- 8) Hartman, T. 2000. "Chiller plant control using gateway technologies." Heating, Piping, Air Conditioning Magazine January.
- 9) Pacific Gas and Electric Company. 2000. "Chilled water plant design guide." A Report of the CoolTools Project.
- 10) Sartor, D., A. Chen. 1996. "Green cooling: improving chiller efficiency." Center for Building Science Newsletter Spring. ❁